

# A1 INSTALLATION DRAWING

IF THIS DOCUMENT IS PRINTED IN HARDCOPY, IT IS FOR INFORMATION USE ONLY AND THEREFORE IS NOT SUBJECT TO UPDATING CONTROLS. ALWAYS REFER TO SOLIDWORKS VIEWER FOR LATEST ISSUE



THIS DRAWING IS CONFIDENTIAL AND IS SUPPLIED ON THE EXPRESS CONDITION THAT IT SHALL NOT BE LOANED OR COPIED OR DISCLOSED TO ANY OTHER PERSON OR USED FOR ANY OTHER PURPOSE WITHOUT THE WRITTEN CONSENT OF AP RACING LTD.



AP Racing  
Wheler Road  
Coventry  
CV3 4LB

Tel: +44 (0) 24 7663 9595  
Fax: +44 (0) 24 7663 9559  
e-mail: [engineering@apracings.com](mailto:engineering@apracings.com)  
Web site: <http://www.apracings.com>

© AP Racing Ltd. 2005

## CP8742 - Ø184.00mm (7.25") CERAMETALLIC INTERNAL DRIVE TWIN PLATE CLUTCH ASSEMBLY

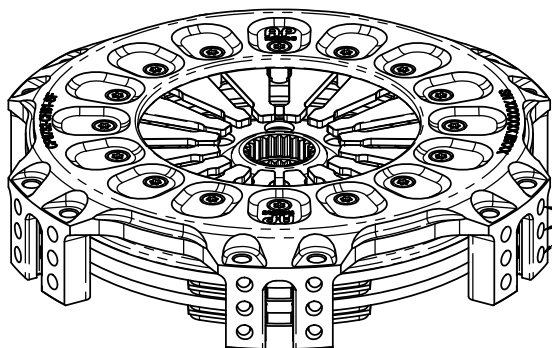

FLAT FLYWHEEL VERSIONS HAVE 2 HOLES ON EACH LUG

### RECOMMENDED RELEASE BEARING :-

STEEL CAGED, ROUND NOSED BALL TYPE BEARING TO BE FREE OF SPRING FINGERS WHEN CLUTCH IS FULLY ENGAGED.  
CP3457-1 STANDARD RELEASE BEARING (OUTER RACE ROTATES)  
CP3457-11 HIGH SPEED RELEASE BEARING (INNER RACE ROTATES)

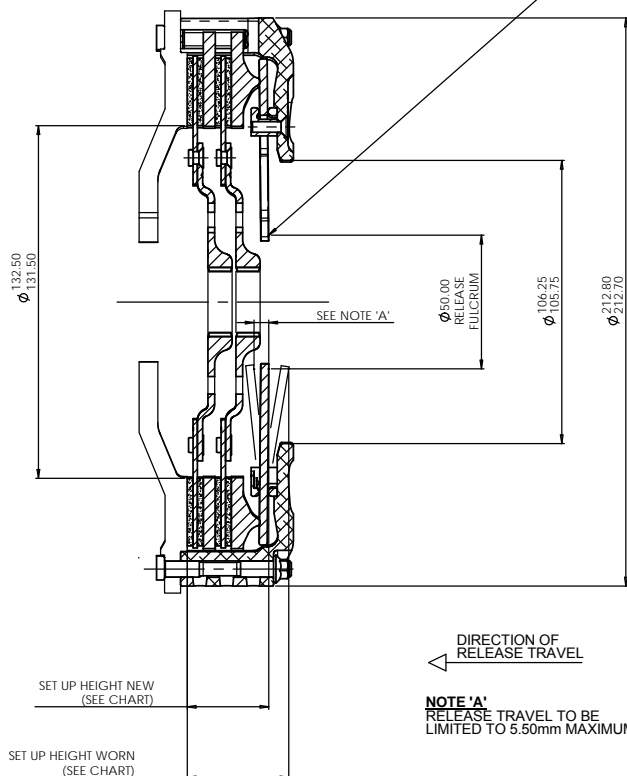

## CP8742 CLUTCH FAMILY

### MAXIMUM DYNAMIC TORQUE CAPACITY

(Nm)	711	785	1016	475	559	735
(ft.lb)	524	579	748	350	411	542

### RELEASE LOAD

Max. Peak Worn (N)	4150	4450	5500	4150	4450	5500
At Travel (N)	2950	3750	4350	2950	3750	4350

### WEAR IN (See Note)

	1.25	1.25	1.25	1.50	1.50	1.50
--	------	------	------	------	------	------

Set Up Height New	32.06	31.80	31.35	31.07	31.92	31.74
	29.90	29.76	29.20	29.31	29.97	29.98
Set Up Height Worn - MAX	37.29	37.03	36.58	36.91	36.68	37.50

(Set Up Height is calculated from the flywheel friction face.)

Release Ratio	4.13	4.13	4.13	3.30	3.30	3.30
---------------	------	------	------	------	------	------

Estimated Assembly Mass (No Driven Plates) = 2.29 Kg

Estimated Assembly Inertia (No Driven Plates) = 0.01480 Kgm<sup>2</sup>

Estimated Driven Plate Inertia - Sheet 3 for details

PERFORMANCE SUFFIX	OE	CE	TE	OH	CH	TH
For Reference						
Diaphragm Spring Rate	ORA	CRV	TGY	ORA	CRV	TGY
Clutch Ratio	EHR	EHR	EHR	HIR	HIR	HIR

MATERIAL SUFFIX	DRIVE PLATE MATERIAL	DRIVE PLATE THICKNESS
81	CERAMETALLIC	6.00mm

FLYWHEEL TYPE		
	SUFFIX	COMMENTS
FLAT FLYWHEEL	FF	FOR INSTALLATION DATA SEE SHEET 2
STEPPED FLYWHEEL	SF	FOR INSTALLATION DATA SEE SHEET 2

Sample AP Racing Part No. **CP8742-CH81-SF**

### WEAR IN

THIS CLUTCH HAS BEEN DESIGNED FOR THE WEAR IN INDICATED ABOVE,

DRIVEN PLATE THICKNESS NEW: 6.00mm Nominal

DRIVEN PLATE THICKNESS WORN (for 1.25 wear in (EHR)) : 5.37mm Minimum

DRIVEN PLATE THICKNESS WORN (for 1.50 wear in (HIR)) : 5.23 mm Minimum

FOR DRIVEN PLATE DETAILS SEE SHEET 3

Issue No.	Alterations			Zone	Initials
	Date & No.	Particulars	#		
1	30/11/11 C4176 C4396	FIRST ISSUE			JO
2	07/11/12 C4396	FLAT FLYWHEEL DETAILS ADDED			JO
3	25/03/14	SUH FOR "CH" OPTION- 31.92/29.97 WAS 31.49/29.82 36.68 WAS 37.33			JO
4	21/02/19 C5206_05	SHEET 3 DRIVE PLATE CP8405-A036H WAS CP7972-A036H CP8375-A036H WAS CP8372-A036H CP8401-A008 & A029 DELETED PICTORIAL CHANGE TO 6 PADDLE PLATE			BJP A12 D10

SCALE 1:1 SHEET 1 OF 3

DRAWN: Jeremy Govan

APPROVED:

DERIVED FROM: cp8032cd / cp8182cd

TITLE  
Ø184mm (7.25") TWIN PLATE CLUTCH INSTALLATION

DRG NO. CP8742CD

# A1 INSTALLATION DRAWING

IF THIS DOCUMENT IS PRINTED IN HARDCOPY, IT IS FOR INFORMATION USE ONLY AND THEREFORE IS NOT SUBJECT TO UPDATING CONTROLS. ALWAYS REFER TO SOLIDWORKS VIEWER FOR LATEST ISSUE



THIS DRAWING IS CONFIDENTIAL AND IS SUPPLIED ON THE EXPRESS CONDITION THAT IT SHALL NOT BE LOANED OR COPIED OR DISCLOSED TO ANY OTHER PERSON OR USED FOR ANY OTHER PURPOSE WITHOUT THE WRITTEN CONSENT OF AP RACING LTD.



AP Racing  
Wheler Road  
Coventry  
CV3 4LB

Tel: +44 (0) 24 7663 9595  
Fax: +44 (0) 24 7663 9559  
e-mail: [engineering@apracings.co.uk](mailto:engineering@apracings.co.uk)  
Web site: <http://www.apracings.com>

© AP Racing Ltd. 2005

## # FLYWHEEL DIMENSIONS

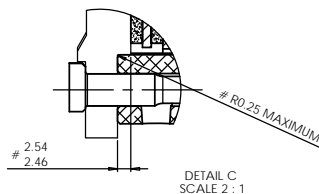
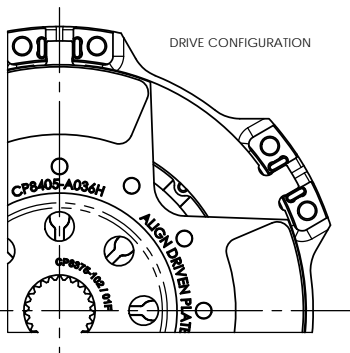
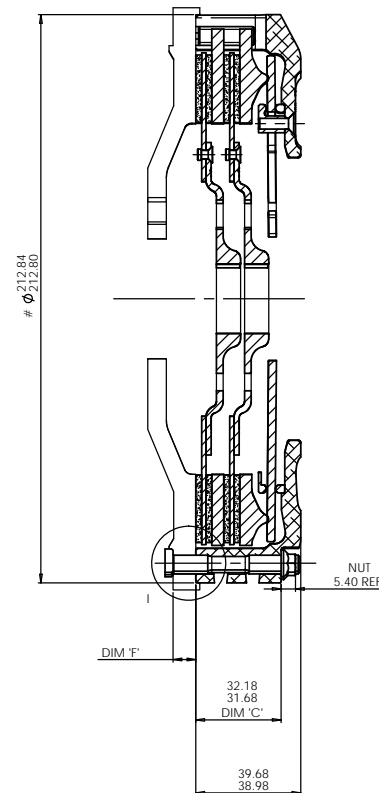
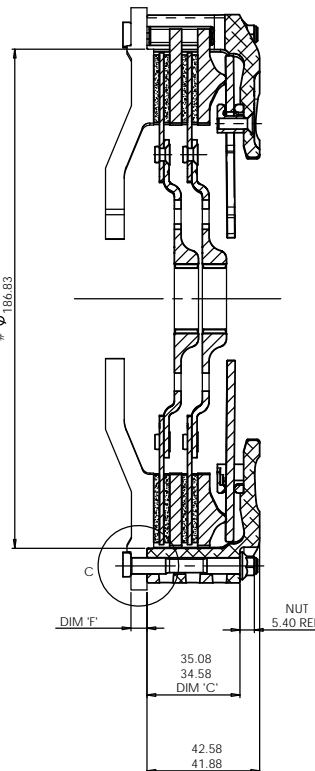
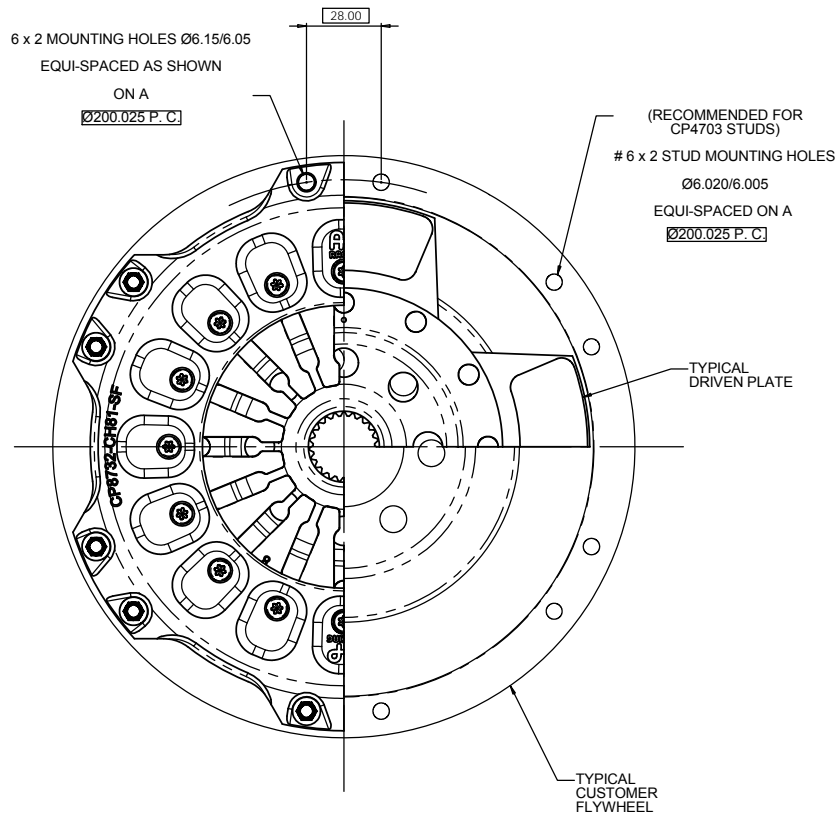

### RECOMMENDED CLUTCH MOUNTING :

(FOR ALL TYPES OF ASSEMBLY)  
M6 x 1.0, CP4703 FAMILY STUD AND  
K-LOCK NUT.  
TIGHTENING TORQUE : 10Nm (7.5 ft.lb)

LENGTH OF STUD REQUIRED TO BE  
CALCULATED THUS :

$$\text{STUD LENGTH} = \text{DIMENSIONS 'C' + 'F' + NUT}$$

THIS CALCULATED LENGTH TO BE ROUNDED  
UP TO THE NEXT AVAILABLE STANDARD STUD  
LENGTH.

### SUGGESTED FLYWHEEL MATERIAL:

0.35/0.45% CARBON STEEL. BRINELL 200 MIN. OR  
SUITABLE MATERIAL FOR HIGH RPM.  
FRICTION FACE TO BE FINE TURNED AND GROUND  
SMOOTH AND FLAT. RUN OUT AT R77.2, ≤0.08  
WHEN ASSEMBLED TO CRANKSHAFT.

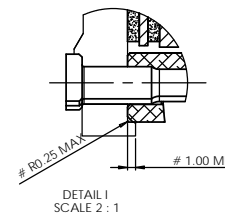

Issue No.	Alterations		
	Date & No.	Particulars	Zone
-	-	SEE SHEET 1 FOR ISSUE INFORMATION.	-

SCALE 1:1	SHEET 2 OF 3
DRAWN	Jeremy Govan
APPROVED	
DERIVED FROM	cp8032cd / cp8182cd
TITLE	
Ø184mm (7.25") TWIN PLATE CLUTCH INSTALLATION	
DRG NO.	CP8742CD

# A1 INSTALLATION DRAWING

IF THIS DOCUMENT IS PRINTED IN HARDCOPY, IT IS FOR INFORMATION USE ONLY AND THEREFORE IS NOT SUBJECT TO UPDATING CONTROLS. ALWAYS REFER TO SOLIDWORKS VIEWER FOR LATEST ISSUE



THIS DRAWING IS CONFIDENTIAL AND IS SUPPLIED ON THE EXPRESS CONDITION THAT IT SHALL NOT BE LOANED OR COPIED OR DISCLOSED TO ANY OTHER PERSON OR USED FOR ANY OTHER PURPOSE WITHOUT THE WRITTEN CONSENT OF AP RACING LTD.

AP Racing Ltd. 2005  
 Tel: +44 (0) 24 7663 9595  
 Fax: +44 (0) 24 7663 9556  
 e-mail: [engineering@apracings.co.uk](mailto:engineering@apracings.co.uk)  
 Web site: <http://www.apracings.com>

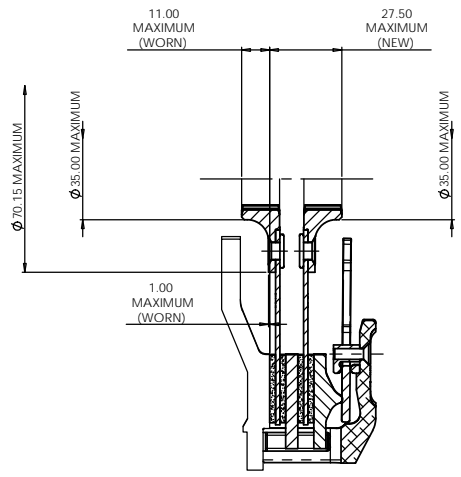

**BACK TO BACK DRIVEN PLATES**  
 Calculated Weight = 0.98kg  
 Calculated Inertia = 0.003569 kg.m<sup>2</sup>  
 Values are for 2 driven plates

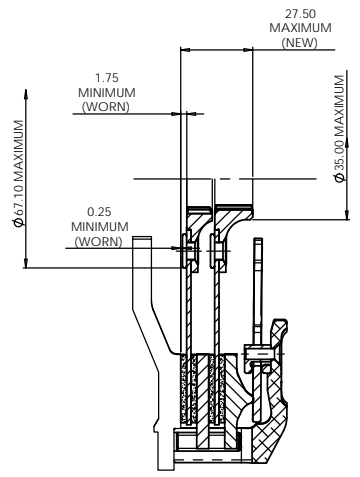

**REDUCED OFFSET DRIVEN PLATES**  
 Calculated Weight = 0.97kg  
 Calculated Inertia = 0.003567 kg.m<sup>2</sup>  
 Values are for 2 driven plates

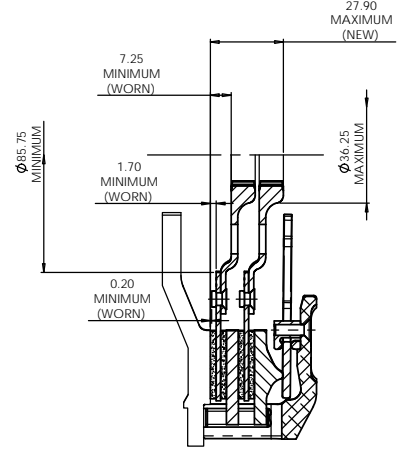

**NESTED DRIVEN PLATES**  
 Calculated Weight = 1.02kg  
 Calculated Inertia = 0.003929 kg.m<sup>2</sup>  
 Values are for 2 driven plates

Issue No.	Alterations		Zone	Initials
	Date & No.	Particulars		
1		SEE SHEET 1 FOR ISSUE INFORMATION.		

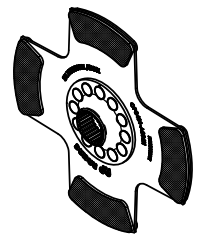
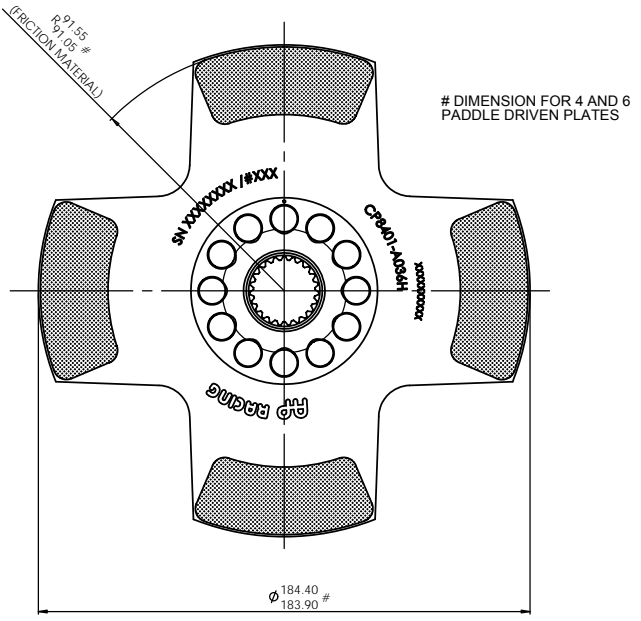

4 PADDLE DRIVEN PLATES (1:2 SCALE)

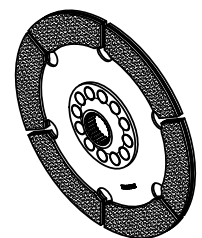

6 PADDLE DRIVEN PLATES (1:2 SCALE)

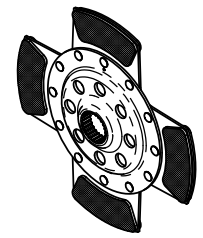

NESTED TYPE DRIVEN PLATES (1:2 SCALE)

DRIVEN PLATE DETAILS							
BACK TO BACK TYPE			REDUCED OFFSET TYPE		NESTED TYPE		
PART NUMBER (4 PADDLE)	NUMBER REQUIRED	SPLINE	PART NUMBER	NUMBER REQUIRED	SPLINE	PART NUMBER	NUMBER REQUIRED
CP8401-A036H	2	1.00" x 23T	CP8401-A036H	1	1.00" x 23T	CP8405-A036H	2
			CP8401-G036H	1	1.00" x 23T		
<b>6 PADDLE</b>							
CP8601-A036H	2	1.00" x 23T	CP8601-A036H	1	1.00" x 23T	CP8375-A036H	2
			CP8601-G036H	1	1.00" x 23T		

SCALE 1:1 SHEET 3 OF 3

DRAWN: Jeremy Govan  
 APPROVED:   
 DERIVED FROM: cp8032cd / cp8182cd

TITLE  
**Ø184mm (7.25") TWIN PLATE CLUTCH INSTALLATION**

DRG NO. CP8742CD