

A2 INSTALLATION DRAWING

If this document is printed in hardcopy, it is for information use only and therefore is not subject to updating controls. Always refer to viewer for latest issue.

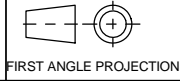

THIS DRAWING IS CONFIDENTIAL AND IS SUPPLIED ON THE EXPRESS CONDITION THAT IT SHALL NOT BE LOANED OR COPIED OR DISCLOSED TO ANY OTHER PERSON OR USED FOR ANY OTHER PURPOSE WITHOUT THE WRITTEN CONSENT OF AP RACING LTD.



AP Racing
Wheler Road
Coventry
CV3 4LB

Tel: +44 024 7663 9595
Fax: +44 024 7663 9559
e-mail: sales@apracings.co.uk
Web site: http://www.apracings.com

© AP Racing Ltd. 2005

Issue No.	Date & No.	Alterations		Zone	Initials
		Particulars			
16	17/10/02 B3471	MIN THR'D DIMS ADDED IMPORTANT NOTE ALSO ADDED			SAT
17	25/02/03 B3438	NOTES AND CHART MODIFIED TO CALL NEW 16.8mm BORE SIZE. INLET TYPE 'A' & 'D' PART No's CORRECTED. 57.15 WAS 57.2 28.57 WAS 28.8			DRA
18	17/03/04 B3430	PUSHROD EXTENSION NOTE ADDED			SAT
19	07/01/08 B5064	INLET TYPE C RESERVOIRS MODIFIED TO MODERN CP4709 TYPE. WAS CP4623 TYPE. OBSOLETE TYPES REMOVED. HEIGHT DATA CHANGED TO COMMON DATUM (C) AS PER OTHER INLET TYPES. PICTORIAL: MAIN BOOT CHANGED TO NEW TYPE.			DRA
20	28/09/09 B5697	NOTES MODIFIED TO REMOVE DETAILS OF EXTRA SHORT CUT OFF OPTION			SAT
21	25/02/15 B7242	DRAWING UPDATED WITH NEW FORMAT SHEET 2 ADDED. VIEWS UPDATED TO SHOW DETAILS OF FORGED BODIES. CP4623-96; 1.0" ASSEMBLY REMOVED. BOOT DIA'S Ø29.50 & Ø35.00 ADDED			SAT

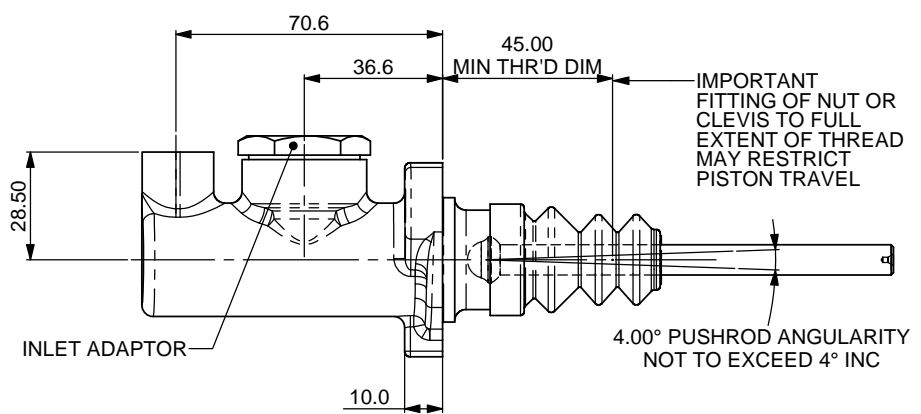
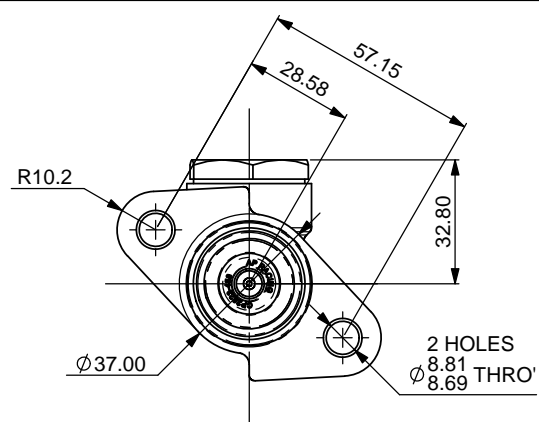

AVAILABLE SIZES OF CYLINDER	
PART NUMBER	BORE SIZE
SMALL BORE CYLINDERS	
CP4623-88	Ø14
CP4623-89	Ø15
CP4623-90	Ø15.9 (5/8")
CP4623-905	Ø16.8
CP4623-91	Ø17.8 (0.70")
CP4623-92	Ø19.1 (3/4")
CP4623-93	Ø20.6
CP4623-94	Ø22.2
LARGE BORE CYLINDERS	
CP4623-95	Ø23.8 (15/16")

GENERAL DESCRIPTION:
LIGHT WEIGHT MASTER CYLINDER FOR USE IN ALL CAR APPLICATIONS. CP4623 MASTER CYLINDER IS SUPPLIED WITH M12 x 1.0 THREADED INLET FOR ALTERNATIVE INLETS & RESERVOIR OPTIONS SEE SHEET 2.

WEIGHT.....295g (0.650LB)
FULL STROKE.....25.4 (1.0")
TRAVEL TO CUT-OFF SHORT.....0.68 TO 1.09 (0.027" TO 0.043")

HYDRAULIC THREADS.....M12 x 1.0 INLET
M10 x 1.0 OUTLET
BODY MATERIAL.....ALUMINIUM ALLOY
TYPICAL APPLICATIONS.....FOR USE IN ALL CARS

INSTALLATION DIMENSIONS FOR 15/16" BORE MASTER CYLINDERS DIFFER FROM OTHER SIZES DUE TO LARGER BOOT. PARTICULAR NOTE SHOULD BE TAKEN OF THE DIFFERENT DIMENSION FROM THE MOUNTING FLANGE TO THE PUSHROD.

FOR REPAIR KITS ADD RK TO BASIC CP2623 EQUIVALENT PART NUMBER, E.G. CP4623-91 ASSEMBLY USES CP2623-91RK

M10 x 1.0 OUTLET AEROQUIP ADAPTOR AVAILABLE

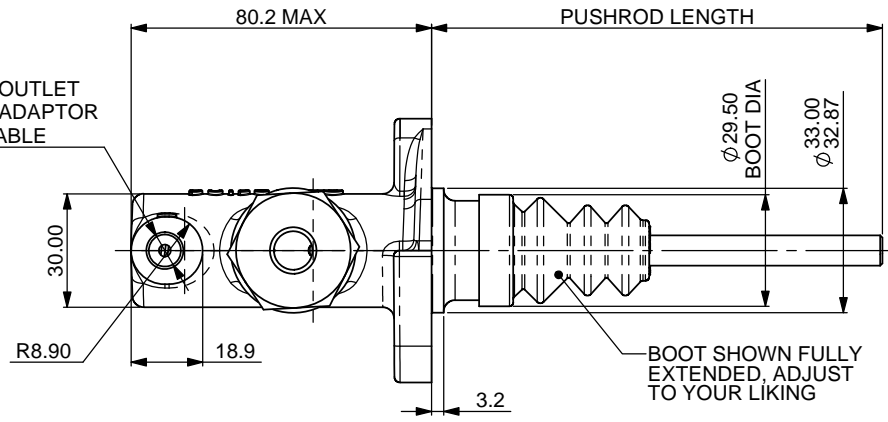

INSTALLATION DIMENSIONS FOR Ø15/16" CYLINDERS

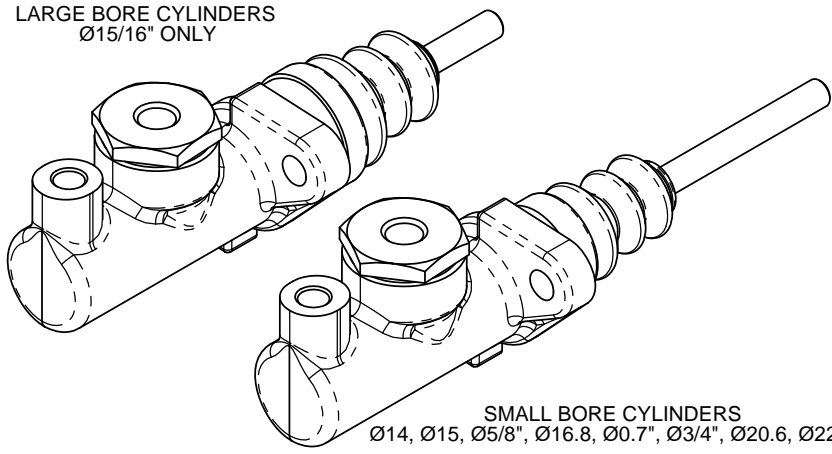
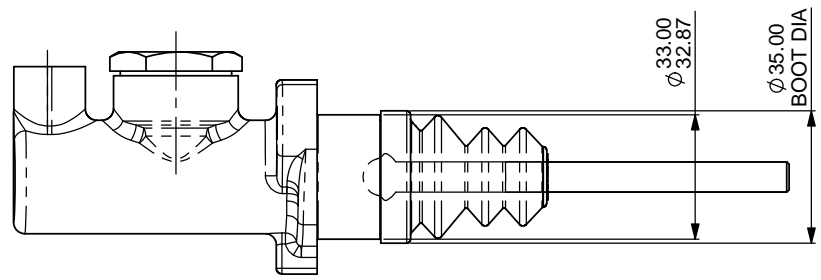

SMALL BORE CYLINDERS Ø14, Ø15, Ø5/8", Ø16.8, Ø0.7", Ø3/4", Ø20.6, Ø22.2

SCALE 1:1	SHEET 1 OF 2
DRAWN	Steve Thomas
APPROVED	
DERIVED FROM	
TITLE OFFSET FLANGE EXTRA SHORT CYLINDER	
DRG NO.	CP4623-1CD

A2 INSTALLATION DRAWING

If this document is printed in hardcopy, it is for information use only and therefore is not subject to updating controls. Always refer to viewer for latest issue.

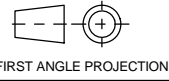

THIS DRAWING IS CONFIDENTIAL AND IS SUPPLIED ON THE EXPRESS CONDITION THAT IT SHALL NOT BE LOANED OR COPIED OR DISCLOSED TO ANY OTHER PERSON OR USED FOR ANY OTHER PURPOSE WITHOUT THE WRITTEN CONSENT OF AP RACING LTD.



AP Racing
 Wheler Road
 Coventry
 CV3 4LB
 Tel: +44 024 7663 9595
 Fax: +44 024 7663 9559
 e-mail: sales@ap racing.co.uk
 Web site: http://www.ap racing.com

ALTERNATIVE INLET OPTIONS

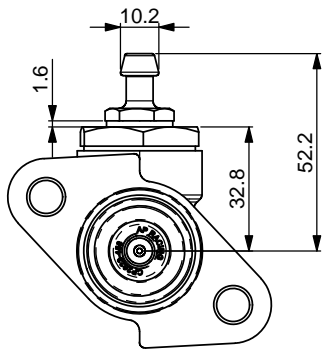

INLET TYPE 'A'
 SELECT MASTER CYLINDER WITH INLET TYPE 'B', PLUS INLET ADAPTOR KIT PART NUMBER CP4623-2

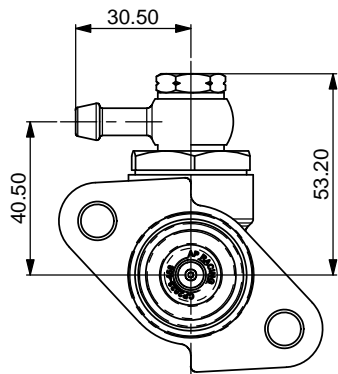

INLET TYPE 'D'
 SELECT MASTER CYLINDER WITH INLET TYPE 'B', PLUS INLET ADAPTOR KIT PART NUMBER CP4623-6

ORDERING:
 WHEN ORDERING PLEASE STATE PUSHROD TYPE AND LENGTH REQUIRED. ALSO SPECIFY WHICH TYPE OF INLET IS REQUIRED.
 e.g. CP4623-90PRT115E INLET TYPE 'A'.
 AP RACING TECHNICAL SECTION WILL BE PLEASED TO ADVISE ON THE MOST SUITABLE EQUIPMENT FOR ANY APPLICATION.

INLET TYPE 'C'
 SELECT MASTER CYLINDER WITH INLET TYPE 'B', PLUS RESERVOIR FROM PART NUMBER CHART BELOW.

PLEASE NOTE:
 TO FIT CP4709 TYPE RESERVOIRS THE INLET ADAPTOR AND COPPER GASKET ARE TO BE REMOVED. FITTING INSTRUCTIONS SUPPLIED WITH RESERVOIR.

RESERVOIR PART No.	HEIGHT 'H' mm (in)	DIA 'E' mm (in)	VOLUME cm ³ (in ³)
CP4709-10	194 (7.64")	51 (2.0")	183 (11.1)
CP4709-11	144 (5.67")	51 (2.0")	123 (7.5)
CP4709-12	104 (4.09")	51 (2.0")	75 (4.5)
CP2293-163	167 (6.57")	89 (3.5")	340 (20.7)

OTHER RESERVOIR OPTIONS AVAILABLE, SEE AP RACING HYDRAULIC ACTUATION CATALOGUE

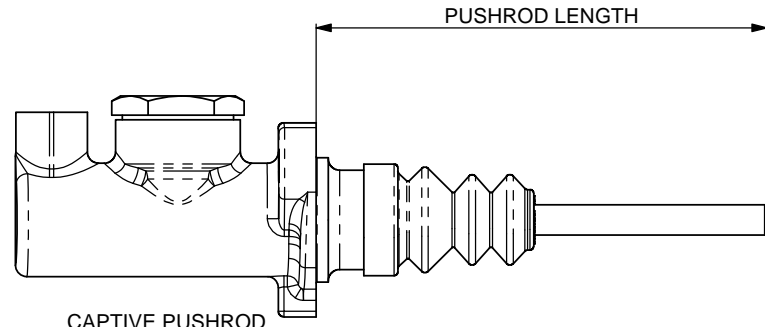

PUSHRODS ARE AVAILABLE IN THE FOLLOWING LENGTHS: 115mm (4.53") AND 160mm (6.3"). NON-STANDARD LENGTHS AVAILABLE ON REQUEST.

CAPTIVE PUSHROD TYPES:
 PRT - PUSH ROD THREADED 5/16" UNF
 PRM - PUSH ROD THREADED M8 x 1.25
 PUSH ROD LENGTHS ARE MEASURED FROM THE MOUNTING FLANGE.

IMPORTANT NOTE:
 CP4623 MASTER CYLINDER IS INDIVIDUALLY SHIMMED DURING ASSEMBLY TO MINIMISE FREE PLAY. THEREFORE PUSH RODS SHOULD NOT BE SWITCHED BETWEEN INDIVIDUAL MASTER CYLINDER ASSEMBLIES.

PUSHROD EXTENTIONS THAT GIVE A TOTAL LENGTH OF OVER 200mm ARE NOT RECOMMENDED. IT IS THE CUSTOMERS RESPONSIBILITY TO CHECK SUITABILITY OF PUSHROD AND EXTENTION PIECES TO TAKE APPLIED LOADS.

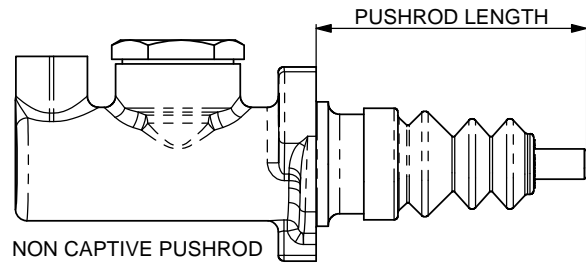

NON CAPTIVE PUSHRODS:
 CP4623 MASTER CYLINDER IS AVAILABLE WITH NON CAPTIVE PUSHRODS. THIS ENABLES THE REMOVAL OF THE MASTER CYLINDER WITHOUT NEED TO REMOVE THE PUSHROD FROM THE BRAKE PEDAL OR BALANCE BAR ASSEMBLY. PUSH RODS ARE AVAILABLE IN LENGTHS EQUIVALENT TO THOSE SHOWN ABOVE.
PUSHROD TYPES:
 NCT - NON CAPTIVE PUSHROD THREADED 5/16" UNF
 NCM - NON CAPTIVE PUSHROD THREADED M8 x1.25

Issue No.	Alterations		Zone	Initials
	Date & No.	Particulars		
		SEE SHEET 1 FOR DETAILS		

SCALE 1:1	SHEET 2 OF 2
DRAWN	Steve Thomas
APPROVED	
DERIVED FROM	
TITLE OFFSET FLANGE EXTRA SHORT CYLINDER	
DRG NO.	CP4623-1CD