

PUBLICATION P12.230

ISSUE: 4

If this document is printed in hardcopy, it is for information use only and therefore is not subject to updating controls. Always refer to viewer for latest issue.

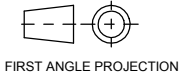

THIS DRAWING IS CONFIDENTIAL AND IS SUPPLIED ON THE EXPRESS CONDITION THAT IT SHALL NOT BE LOANED OR COPIED OR DISCLOSED TO ANY OTHER PERSON OR USED FOR ANY OTHER PURPOSE WITHOUT THE WRITTEN CONSENT OF AP RACING LTD.



AP Racing
Wheler Road
Coventry
CV3 4LB

Tel: +44 024 7663 9595
Fax: +44 024 7663 9599
e-mail: sales@apracings.co.uk
Web site: HTTP://www.apracings.com

BMW Z4 M COUPE KIT NUMBER CP5575-1010		
Ref	DESCRIPTION	QTY
1	BRAKE DISC LEFT HAND BRAKE DISC RIGHT HAND	1 1
2	MOUNTING BELL	2
3	CALIPER LEFT HAND CALIPER RIGHT HAND	1 1
4	MOUNTING BRACKET	2
5	M12 x 70 CALIPER Mtg BOLT	4
6	M12 x 43 BRACKET Mtg BOLT	4
7	DISC WASHER	48
8	0.25UNF DISC Mtg BOLT	24
9	0.25UNF DISC Mtg NUT	24
10	GASKET	4
11	HOSE KIT	2
12	BANJO BOLT	2
13	NYLON ARMOUR	2
14	Ø 18.4 O.D. CALIPER WASHER	4
15	Ø 27.6 O.D. BRACKET WASHER	4
16	0.5mm BRACKET SHIM	12
17	CALIPER PAD SET (4)	1
18	ANTI RATTLE CLIP	2

Tightening Torques	
Part Ref #	Torque
Bolt Ref 5	68NM
Bolt Ref 6	68NM
Bolt/Nut Ref 8/9	14NM
Banjo Bolt Ref 12	25NM
Caliper Bleed Screw	17NM

BRAKE DISC WEAR	
NEW	MIN WORN
32.00mm	31.00mm

NOTE:
PLEASE USE ORIGINAL BMW GROMMET TO LOCATE THE AP RACING HOSE.
ENSURE SPLASH GAURD DOES NOT FOUL ON DISC FACE, BEND AS NECESSARY PAYING ATTENTION TO LOWER STEERING KNUCKLE.

Comments
Check caliper is central over disc, use 0.5mm shims (Part Ref 16) to adjust bracket if required
Illustration is of left hand assembly

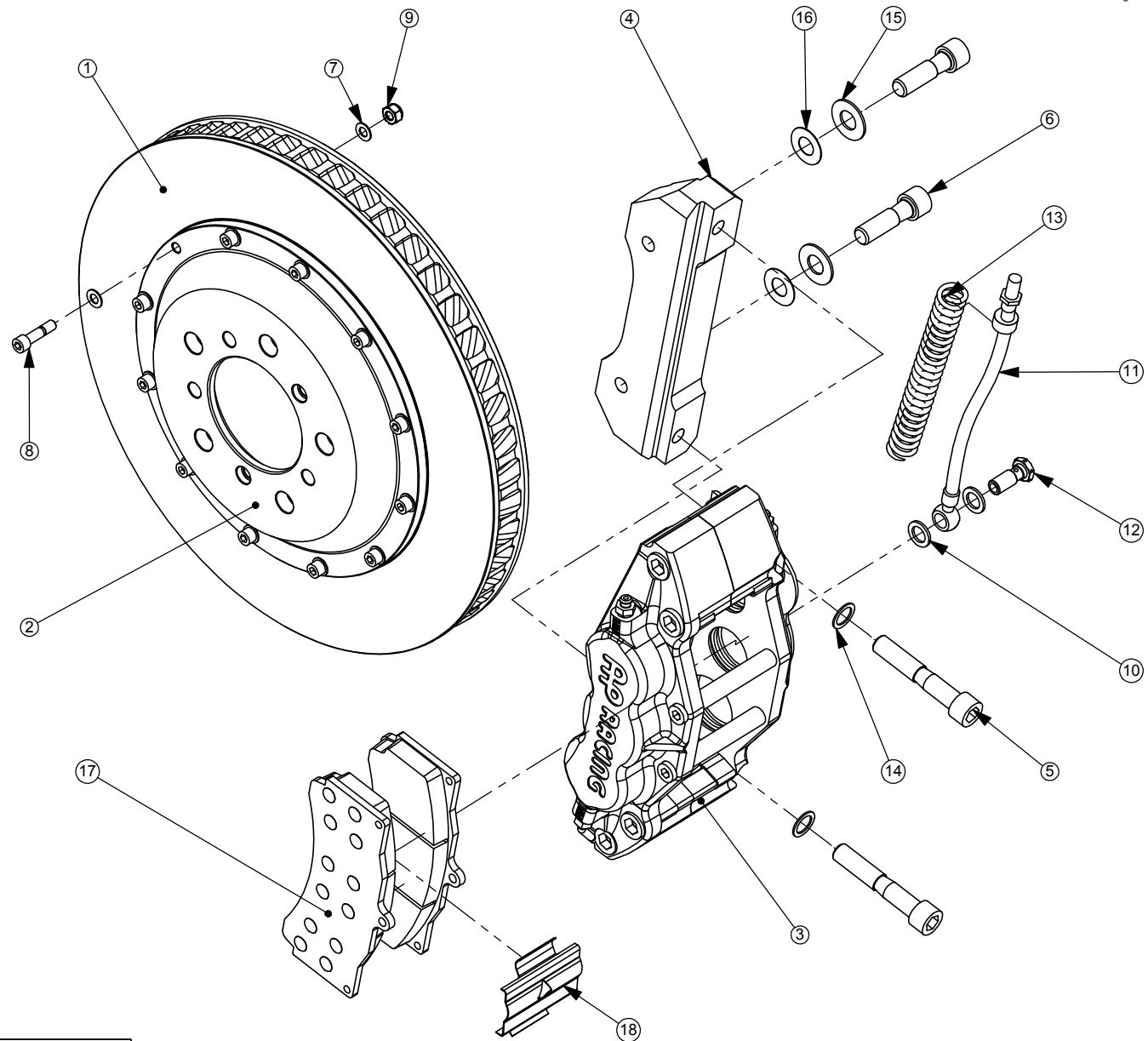

PLEASE RETAIN THIS SHEET FOR FUTURE REFERENCE

THIS IS A PICTORIAL VIEW FOR REFERENCE ONLY. SOME PARTS MAY VARY FROM THOSE SUPPLIED. AP RACING RESERVE THE RIGHT TO CHANGE COMPONENTS WITHOUT PRIOR NOTICE.
Drawn By: Lee Stretch