

A1 INSTALLATION DRAWING

IF THIS DOCUMENT IS PRINTED IN HARDCOPY, IT IS FOR INFORMATION USE ONLY AND THEREFORE IS NOT SUBJECT TO UPDATING CONTROLS. ALWAYS REFER TO SOLIDWORKS VIEWER FOR LATEST ISSUE



THIS DRAWING IS CONFIDENTIAL AND IS SUPPLIED ON THE EXPRESS CONDITION THAT IT SHALL NOT BE LOANED OR COPIED OR DISCLOSED TO ANY OTHER PERSON OR USED FOR ANY OTHER PURPOSE WITHOUT THE WRITTEN CONSENT OF AP RACING LTD.



AP Racing
Wheler Road
Coventry
CV3 4LB

Tel: +44 (0) 24 7663 9595
Fax: +44 (0) 24 7663 9559
e-mail: engineering@apracings.com
Web site: http://www.apracings.com

© AP Racing Ltd. 2005

GENERAL DESCRIPTION

4 PISTON, DIFFERENTIAL BORE, TWO PIECE CALIPER, FOR USE WITH DISCS UP TO Ø320.00 MAX, WITH A WIDTH OF 6.0 - 7.1mm.

TYPICAL APPLICATION

MOTORCYCLE ENGINED VEHICLES, HIGH PERFORMANCE ROAD.

TECHNICAL & INSTALLATION INFORMATION

TOTAL PISTON AREA = 36.19 cm²
PISTON MATERIAL - ALUMINIUM ALLOY (STANDARD)
BODY MATERIAL - ALUMINIUM ALLOY (STANDARD)
HYDRAULIC FEED - M10X1.0, BLEED SCREW - M7X1.0
TYPICAL MOUNTING BOLT TIGHTENING TORQUE (FOR GUIDANCE ONLY) - 54Nm (M10)
ASSEMBLY WEIGHT - 0.82kg

KEY TO DIMENSIONS

DIMENSION 'PL' TOP OF PAD MATERIAL TO MOUNTING BOSS FACE
WITH PAD SITTING DOWN ON LEDGE.

DIMENSION 'C' DISC CENTRE LINE TO MOUNTING STUD CENTRE LINE.

DIMENSION 'U' WHEEL CENTRE TO CALIPER MOUNTING BOSS FACE
(DISC DIAMETER/2 - 'PL' DIMENSION).

DIMENSION 'H' MOUNTING HOLE DIAMETER.

RADIUS 'N' RADIUS OF DISC PATHWAY.

EFFECTIVE RAD DISTANCE FROM WHEEL CENTRE LINE TO NOMINAL PISTON CENTRE LINE.

CALIPER PART NUMBERS

CP7853-2E0 RIGHT HAND.
CP7853-3E0 LEFT HAND.

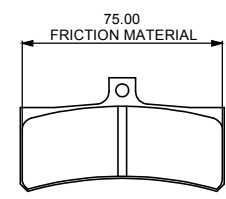
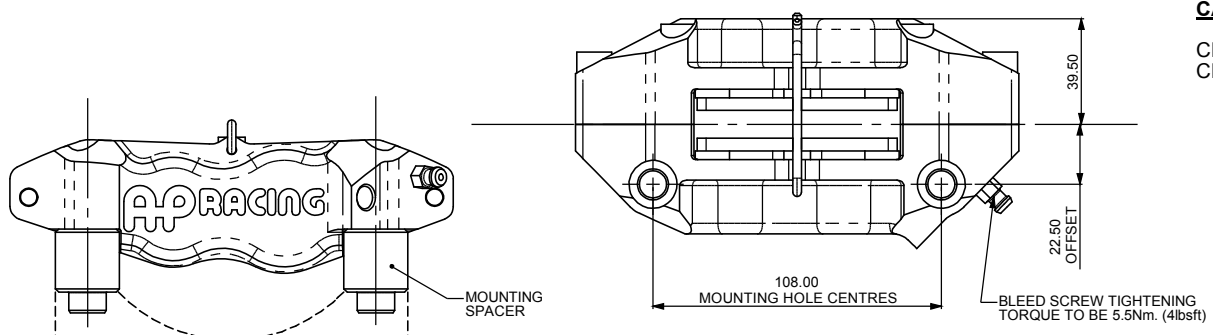
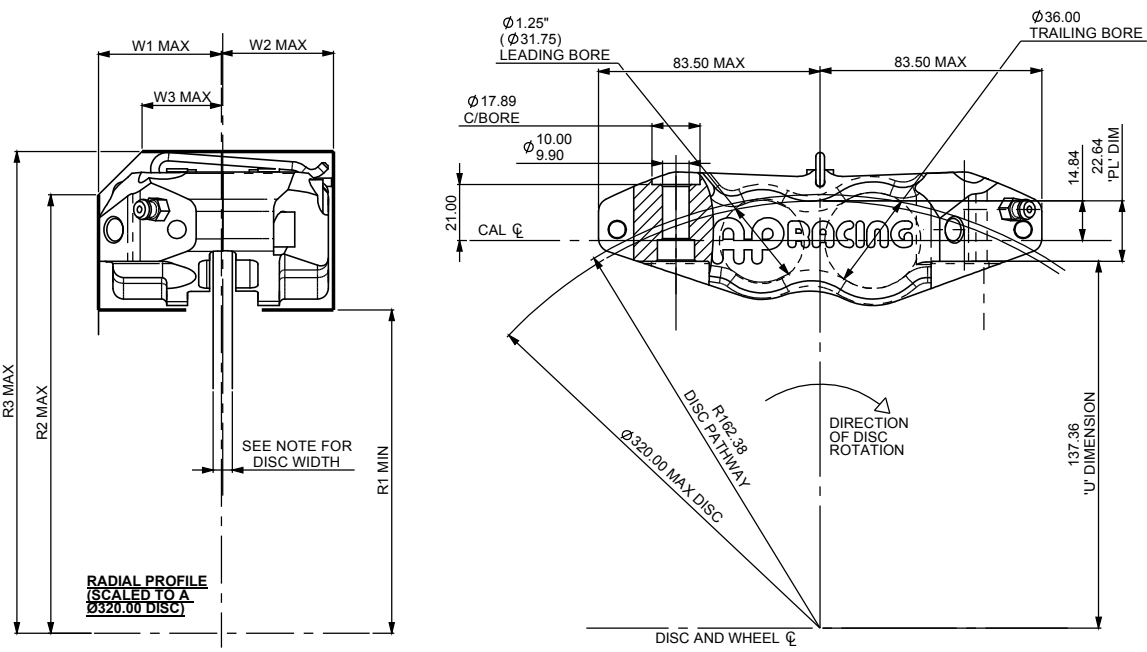

CP4484D27-*** PAD FAMILY
PAD THICKNESS - 8.0mm
PAD AREA - 1867mm²
WEAR VOLUME - 8962mm³

AS SHOWN ABOVE A MOUNTING SPACER IS REQUIRED WITH THIS CALIPER. THE RADIAL PROFILE DATA TABLE PROVIDES A GUIDE AS TO WHICH SPACER IS REQUIRED FOR A RANGE OF DISC DIAMETERS

RADIAL PROFILE DATA

DISC Ø	W1	W2	W3	R1	R2	R3	EFF RAD	U' DIMENSION	SPACER REQUIRED	COMMENTS
320.00	46.00	42.00	29.71	121.10	164.21	180.50	145.16	137.36	CP7853-106	SPACER SUPPLIED WITH CALIPER
300.00	46.00	42.00	29.30	111.25	157.23	171.60	135.16	127.36	CP7853-107	
290.00	46.00	42.00	23.23	106.30	150.20	167.50	130.16	122.36	CP7853-108	

Issue No	Alterations		Zone	Initials
	Date & No.	Particulars		
1	03/03/04 B3819	FIRST ISSUE		
2	16/09/2010 B6031	SHEET 2 ADDED		

SCALE 1:1	SHEET 2 OF 2
DRAWN	I Morrish
APPROVED	
DERIVED FROM	
TITLE	4 POT MOTORCYCLE CALIPER
DRG NO.	CP7853-1CD

A1 INSTALLATION DRAWING

IF THIS DOCUMENT IS PRINTED IN HARDCOPY, IT IS FOR INFORMATION USE ONLY AND THEREFORE IS NOT SUBJECT TO UPDATING CONTROLS. ALWAYS REFER TO SOLIDWORKS VIEWER FOR LATEST ISSUE



THIS DRAWING IS CONFIDENTIAL AND IS SUPPLIED ON THE EXPRESS CONDITION THAT IT SHALL NOT BE LOANED OR COPIED OR DISCLOSED TO ANY OTHER PERSON OR USED FOR ANY OTHER PURPOSE WITHOUT THE WRITTEN CONSENT OF AP RACING LTD.



AP Racing
Wheler Road
Coventry
CV3 4LB

Tel: +44 (0) 24 7663 9595
Fax: +44 (0) 24 7663 9559
e-mail: engineering@apracings.co.uk
Web site: <http://www.apracings.com>

© AP Racing Ltd. 2005

SPARE PARTS LIST

REF	QTY / CALIPER	DESCRIPTION	PART No.
1	2	PISTON (36.0mm)	CP4488-106
2	2	PISTON (1.250")	CP4488-107
3	1	SEAL KIT	CP4518-EH
4	1	BLEEDSCREW	CP4469-101
5	1	PAD RETAINER CLIP	CP3696-106

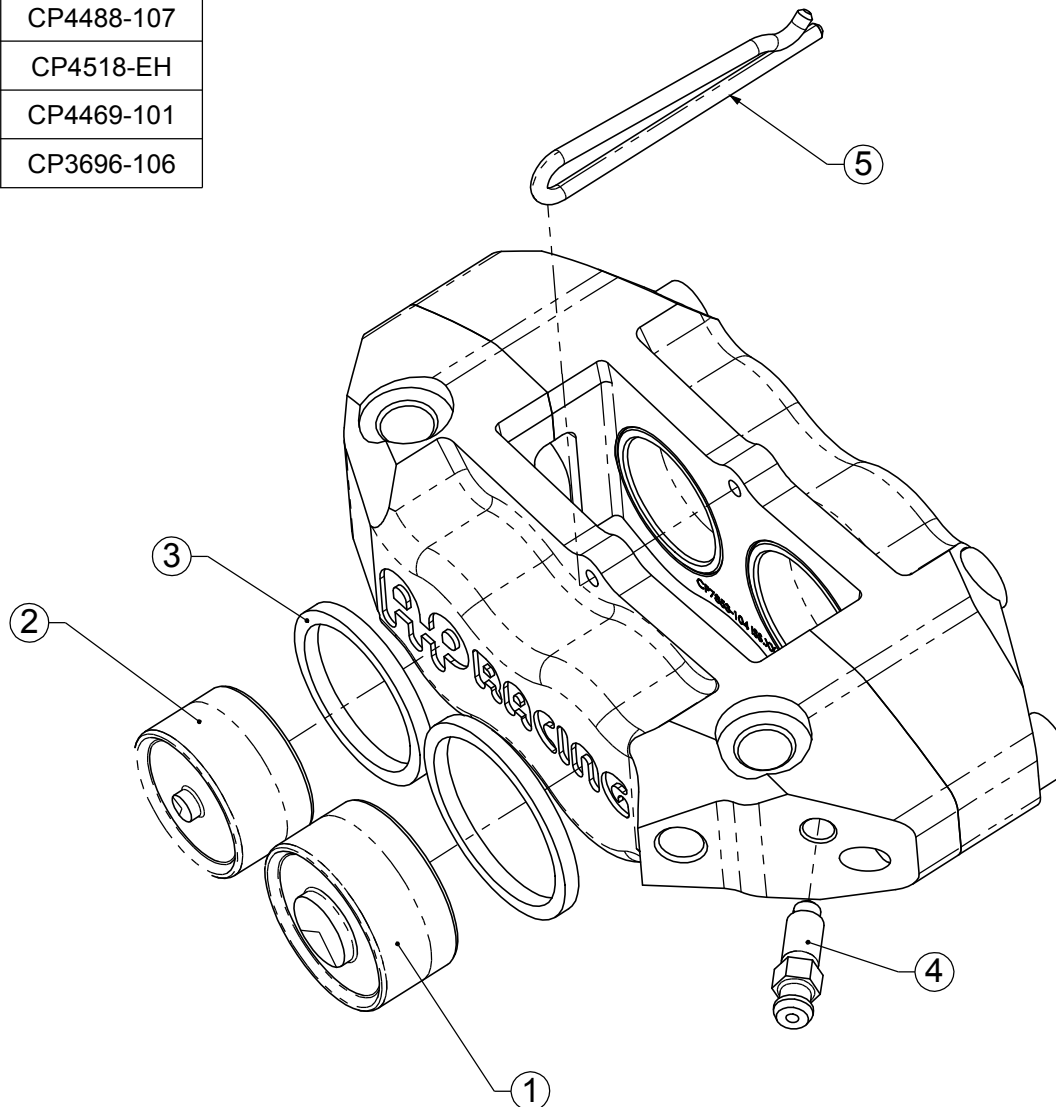

Issue No.	Alterations		Zone	Initials
	Date & No.	Particulars		
-	-	SEE SHEET 1 FOR ISSUE INFORMATION.	-	-

SCALE 1:1		SHEET 2 OF 2	
DRAWN	I Morrish		
APPROVED			
DERIVED FROM			
TITLE			
4 POT MOTORCYCLE CALIPER			
CALIPER			
DRG NO.	CP7853-1CD		