

B1 INSTALLATION DRAWING

IF THIS DOCUMENT IS PRINTED IN HARD COPY, IT IS FOR INFORMATION USE ONLY AND THEREFORE IS NOT SUBJECT TO UPDATING CONTROLS. ALWAYS REFER TO SOLIDWORKS VIEWER FOR LATEST ISSUE



THIS DRAWING IS CONFIDENTIAL AND IS SUPPLIED ON THE EXPRESS CONDITION THAT IT SHALL NOT BE LOANED OR COPIED OR DISCLOSED TO ANY OTHER PERSON OR USED FOR ANY OTHER PURPOSE WITHOUT THE WRITTEN CONSENT OF AP RACING LTD.

AP Racing
Wheler Road
Coventry
CV3 4LB
Tel: +44 024 7683 9595
Fax: +44 024 7683 9559
e-mail: sales@apracings.co.uk
Web site: HTTP://www.apracings.com

GENERAL DESCRIPTION
6 PISTON DIFFERENTIAL BORE CALIPER TO SUIT UP TO Ø355 x 35 CARBON DISC & UP TO Ø355 x 35.6 IRON DISC

APPLICATION
GT CARS

TECHNICAL INFORMATION
TOTAL PISTON AREA: 50.10cm²
PISTON MATERIAL: TITANIUM
BODY MATERIAL: ALUMINIUM ALLOY
ASSEMBLY WEIGHT: 2.25KG

INSTALLATION INFORMATION
DISC & CALIPER MOUNTING TOLERANCES TO BE SUCH THAT THE DISC IS CENTRAL TO THE CALIPER TO WITHIN ±0.5mm.
CALIPER TO BE MOUNTED WITHIN ±15° FROM VERTICAL.
DISC DIAMETRAL CLEARANCE SHOULD BE 2.5mm NOM. FROM DISC O.D. TO PATHWAY.

MINIMUM WORN DISC & PAD STACK = 40.7mm

CALIPER PART NUMBERS

CP6078-4S7MP - RIGHT HAND LEADING (AHEAD OF AXLE)
CP6078-5S7MP - LEFT HAND LEADING (AHEAD OF AXLE)
CP6078-4S7MPD - RIGHT HAND LEADING (AHEAD OF AXLE) INC. DUCT
CP6078-5S7MPD - LEFT HAND LEADING (AHEAD OF AXLE) INC. DUCT

DUCT KIT CAN ALSO BE ORDERED SEPARATELY, UNDER PART NUMBER CP6078-107 (NON-HANDED). SEE SHEET 2 FOR INSTALLATION DETAIL.

NOTE: CALIPERS CAN BE USED IN A TRAILING (BEHIND AXLE) POSITION BY SWAPPING THE INLET ADAPTOR AND BLEED SCREW OVER.

SEE SHEET 3 FOR SPARE PARTS LIST

'P' SUFFIX DENOTES CALIPER WITH PROVISION FOR PISTON CAPS. FOR PISTON CAP PART NUMBERS SEE CP6060-1PCD DRAWING.

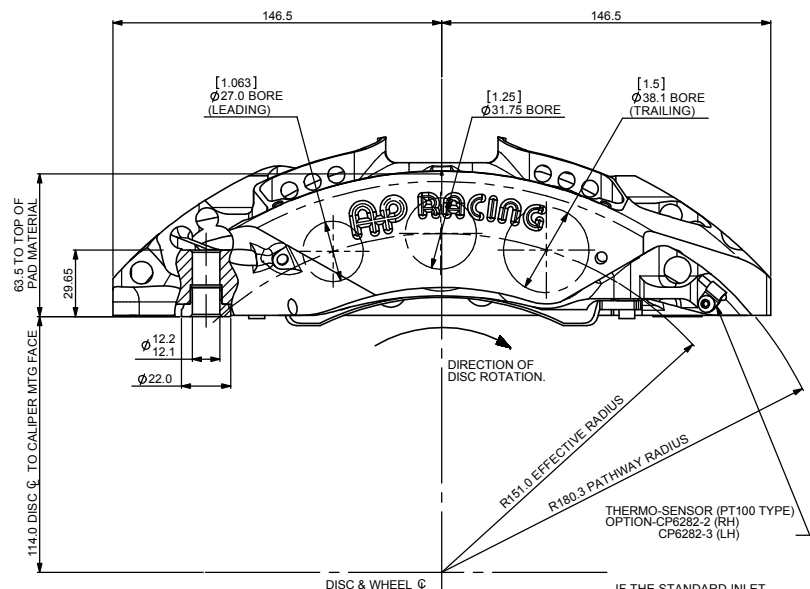
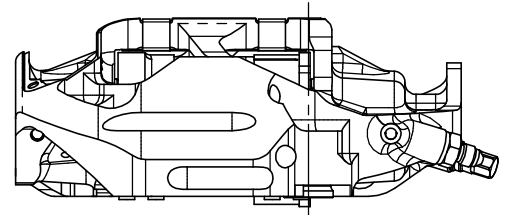

IF THE STANDARD INLET FITTING IS NOT USED, ENSURE THE REPLACEMENT HAS AT LEAST 12mm OF ENGAGEMENT IN THE PORT.

CP6300-21 DRY BREAK FITTING TIGHTENING TORQUE 13Nm. APPLY LOCTITE 270 TO THREAD UPON ASSEMBLY

FOR FURTHER DRY BREAK INFORMATION & SPARES REFER TO CP6300-13CD INSTALLATION DRAWING.

NOTE: DRY BREAK AND INLET ADAPTOR SHOULD BE SWAPPED OVER IF THE CALIPER IS TO BE USED IN A TRAILING POSITION.

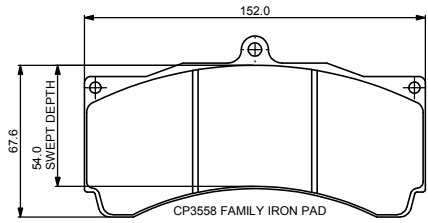
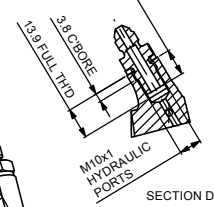

CP3558 FAMILY IRON PAD

PAD AREA
-SLOTTED: 77.43cm²
-FULL AREA: 80.17cm²
PAD THICKNESS: 25mm

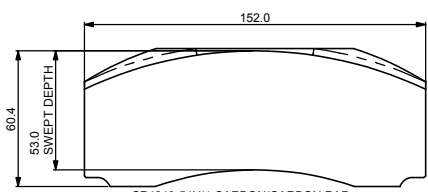

CP4240-54H** CARBON/CARBON PAD

PAD AREA: 78.12cm²
PAD THICKNESS: 25mm

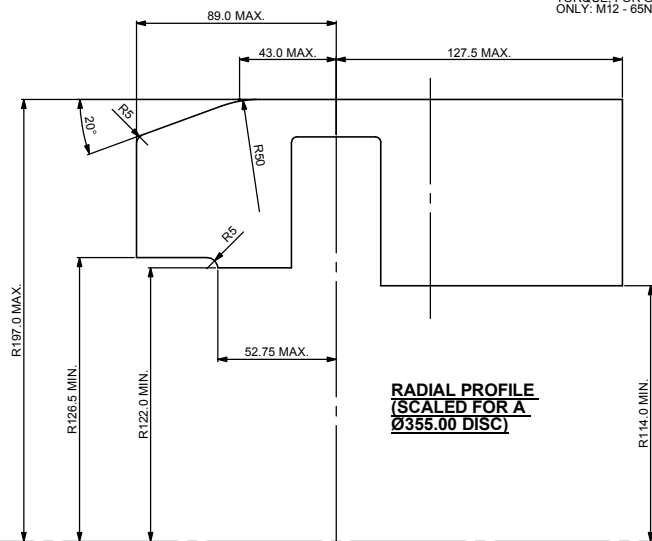

RADIAL PROFILE (SCALED FOR A Ø355.00 DISC)

TYPICAL MTG TIGHTENING TORQUE FOR GUIDANCE ONLY: M12 - 65Nm & M10 - 54Nm

Ø20 MIN SPOTFACE

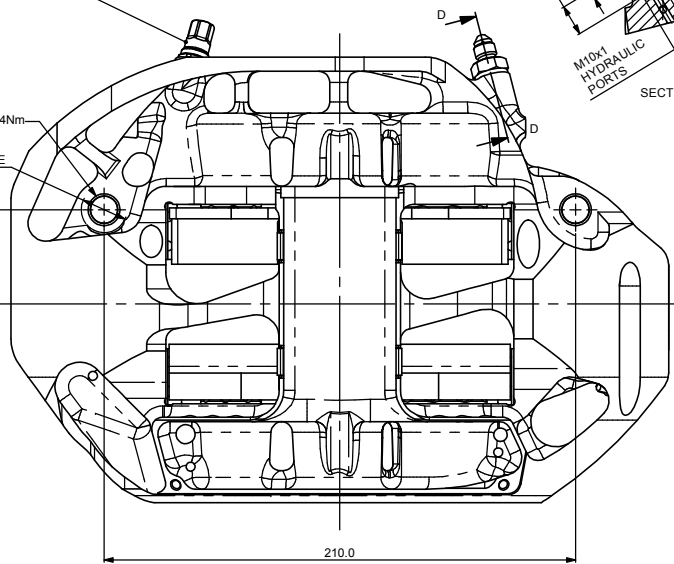

WHEN RUNNING CP3558 IRON PADS THE PAD SUPPORTS MUST BE FITTED SO THAT THE LETTERS 'I' ON THE PAD SUPPORTS FACE EACH OTHER AS SHOWN.

WHEN RUNNING CP4240 CARBON PAD THE PAD SUPPORTS MUST BE FITTED SO THAT THE LETTERS 'C' ON THE PAD SUPPORTS FACE EACH OTHER.

APR RECOMMEND THE USE OF A THREADLOCKER (LOCTITE 243 OR SIMILAR) ON THE PAD SUPPORT RETAINING SCREWS.

CARBON SET-UP = LETTERS 'C' FACE EACH OTHER

IRON SET-UP = LETTERS 'I' FACE EACH OTHER

Alterations				
Date & No.	Particulars	Zone	Initials	
1 AUG 08 B5071	FIRST ISSUE			JT
2 19 NOV 08 B5354	DUCT KIT PART # CHANGED - CP6078-107 WAS CP6078-6			JT
3 14/07/09 B5609	ALTERNATIVE PAD SUPPORT ADDED TO SPARES TABLE [SHT 3]			RLB

SCALE 1:1 SHEET 1 OF 3

DRAWN Jon Tait

APPROVED

DERIVED FROM CP6088-1CD

TITLE
6 PISTON MONOBLOC
RADICAL GT CALIPER

DRG NO. CP6078-1CD

B1 INSTALLATION DRAWING

IF THIS DOCUMENT IS PRINTED IN HARDCOPY, IT IS FOR INFORMATION USE ONLY AND THEREFORE IS NOT SUBJECT TO UPDATING CONTROLS. ALWAYS REFER TO SOLIDWORKS VIEWER FOR LATEST ISSUE

FIRST ANGLE PROJECTION

THIS DRAWING IS CONFIDENTIAL AND IS SUPPLIED ON THE EXPRESS CONDITION THAT IT SHALL NOT BE LOANED OR COPIED OR DISCLOSED TO ANY OTHER PERSON OR USED FOR ANY OTHER PURPOSE WITHOUT THE WRITTEN CONSENT OF AP RACING LTD.



AP Racing
Wheler Road
Coventry
CV3 4LB
Tel: +44 024 7663 9595
Fax: +44 024 7663 9559
e-mail: sales@apracing.co.uk
Web site: HTTP://www.apracing.com

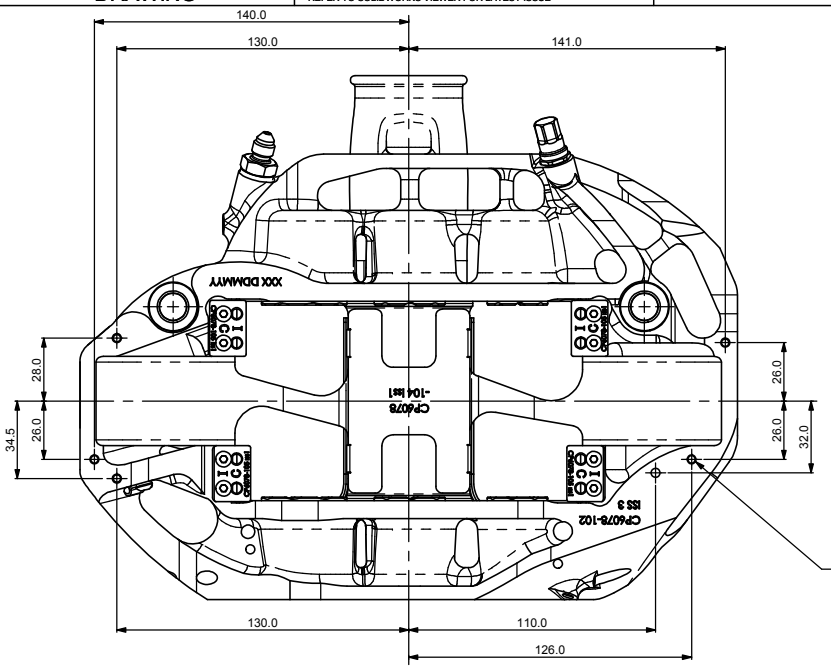

3 HOLES M4x0.7 x 8 FULL THD EACH END OF CALIPER FOR MOUNTING WHEEL SCRAPER.

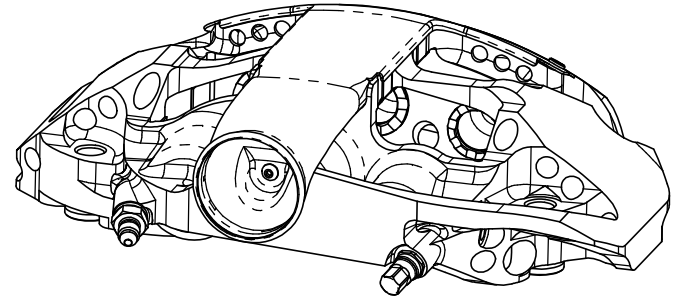
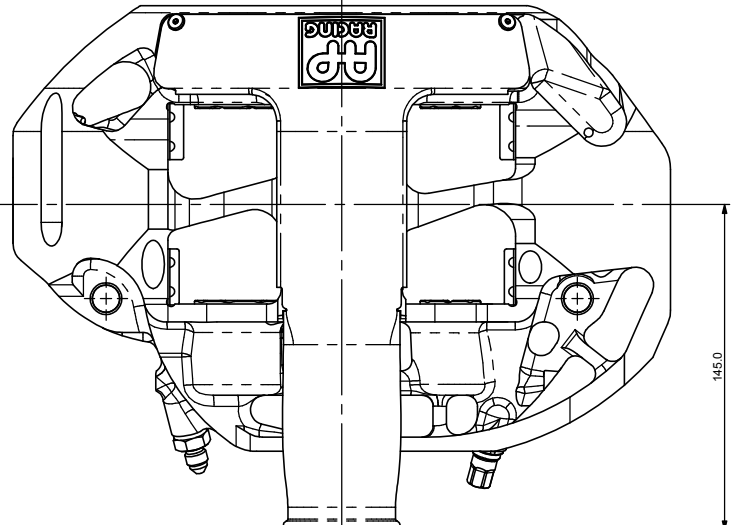
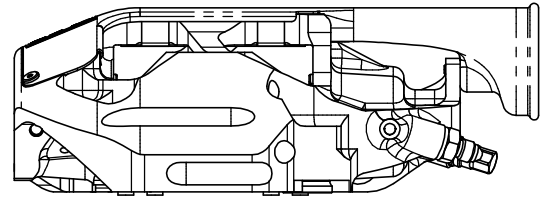
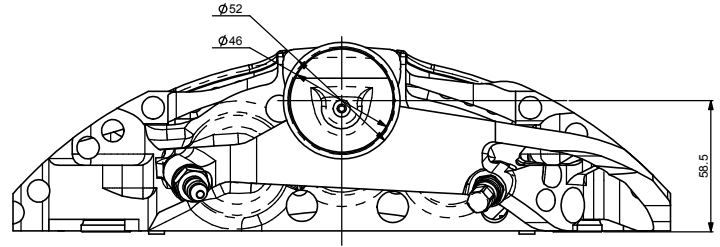
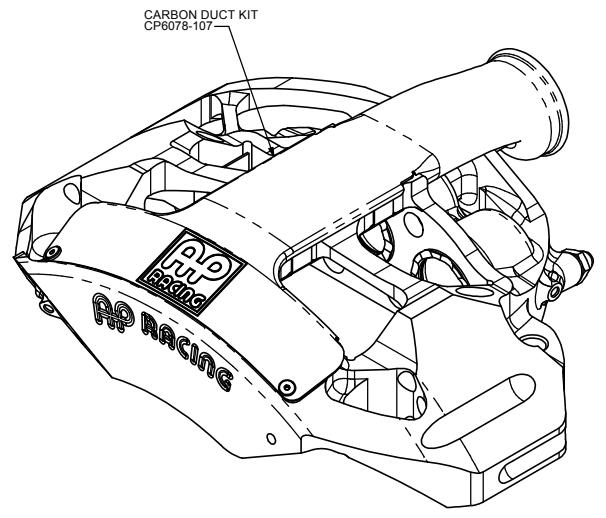

Alterations		Zone	Initials
Date & No.	Particulars		
3	SEE SHEET 1 FOR ISSUE CHANGE DETAILS		

SCALE 1:1	SHEET 1 OF 3
DRAWN Jan Tait	
APPROVED	
DERIVED FROM CP6088-1CD	
TITLE	
6 PISTON MONOBLOC RADICAL GT CALIPER	
DRG NO.	CP6078-1CD

B1 INSTALLATION DRAWING

IF THIS DOCUMENT IS PRINTED IN HARDCOPY, IT IS FOR INFORMATION USE ONLY AND THEREFORE IS NOT SUBJECT TO UPDATING CONTROLS. ALWAYS REFER TO SOLIDWORKS VIEWER FOR LATEST ISSUE



THIS DRAWING IS CONFIDENTIAL AND IS SUPPLIED ON THE EXPRESS CONDITION THAT IT SHALL NOT BE LOANED OR COPIED OR DISCLOSED TO ANY OTHER PERSON OR USED FOR ANY OTHER PURPOSE WITHOUT THE WRITTEN CONSENT OF AP RACING LTD.

AP RACING
 AP Racing
 Wheler Road
 Coventry
 CV3 4LB
 Tel: +44 024 7663 9595
 Fax: +44 024 7663 9599
 e-mail: sales@apracings.co.uk
 Web site: HTTP://www.apracings.com
 © AP Racing Ltd. 2005

SPARE PARTS LIST			
REF	QTY / CALIPER	PART NO.	DESCRIPTION
1	1	CP6518-7LBSSL	7.00LB AKB SPRING KIT
2	2	CP6055-112	Ø1.50" PISTON
3	2	CP6055-111	Ø1.25" PISTON
4	2	CP6055-110	Ø1.06 PISTON
5	1	CP4518-CEJ	HIGH-TEMP SEAL KIT (6 SEALS)
6	1	CP6300-21	M10 DRY-BREAK CONNECTOR
7	2	CP6056-106	MOUNTING BOSS
8	1	CP6160-107	INLET FITTING
9	4	CP6075-105	WEARPLATE
10	4	CP6078-105	PAD SUPPORT
		CP6078-108	ALTERNATIVE PAD SUPPORT FOR IRON PAD SET-UP ONLY
11	8	CP3215-115	M4 SCREW
12	1	KL44517	COPPER GASKET
13	1	CP6078-104	CENTRE WEARPLATE

FOR CALIPER RE-CONDITIONING INFORMATION SEE AP RACING DATA SHEET P14.101

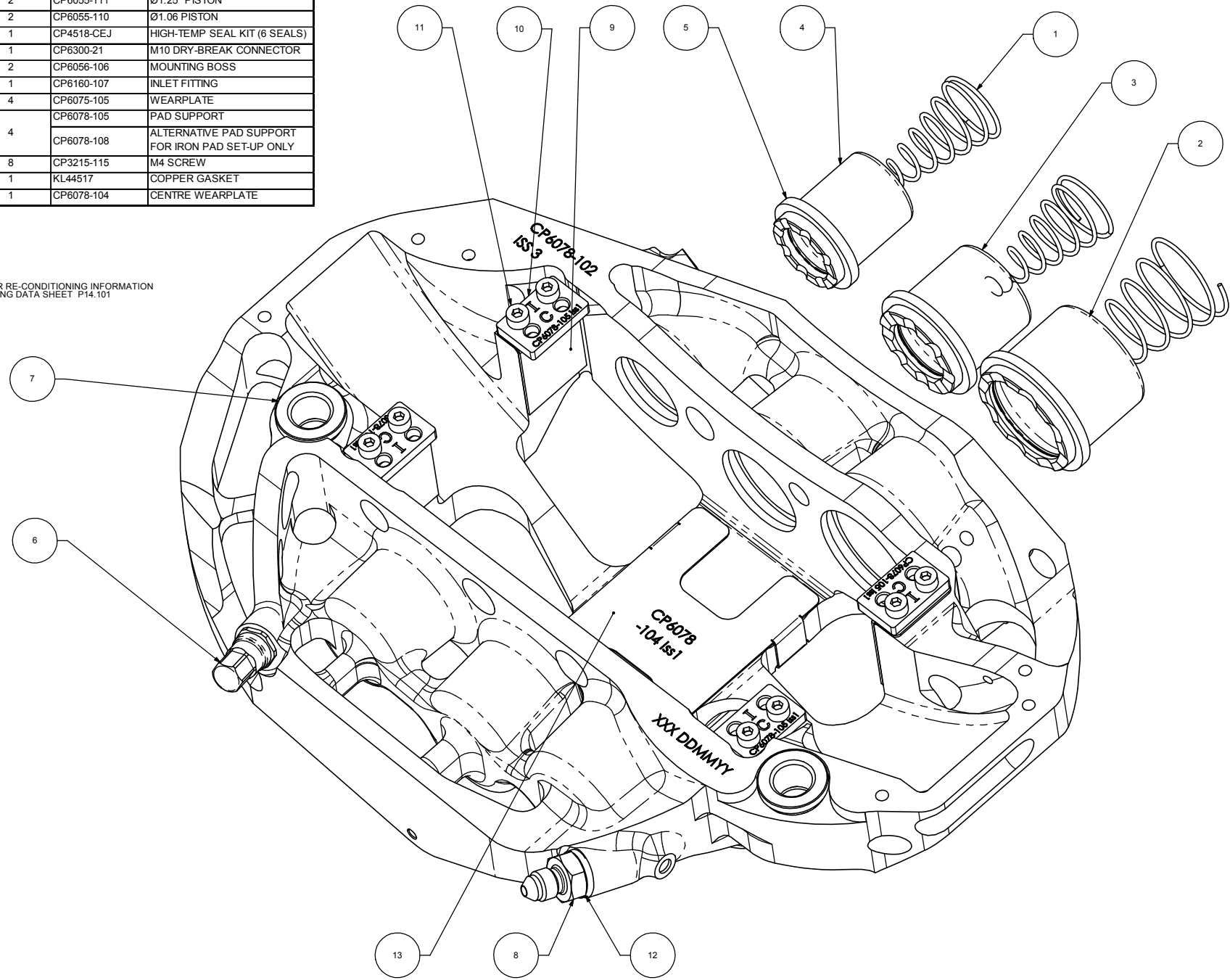

Issue No.	Alterations		Zone	Initials
	Date & No.	Particulars		
3		SEE SHEET 1 FOR ISSUE CHANGE DETAILS		

SCALE 1:1 SHEET 1 OF 3
 DRAWN Jon Tait
 APPROVED
 DERIVED FROM
 TITLE
**6 PISTON MONOBLOC
 RADICAL GT CALIPER**
 DRG NO. CP6078-1CD